



Specification of LED Inground Light

1. General Introduction:

The Inground lights is a good choice for the garden light, and landscape light, we also called it LED Floor light, LED Spot light.

The inground light adopts High power LED or SMD LEDs as the light source, there are many advantages when compares to the normal inground light, such as energy-saving, environment protection, high brightness, anti-shock, anti-vibration, purity color, and long lifespan, about 50,000 hours.

With IP67 rank and $-20 \sim 45$ working temperature $^{\circ}\text{C}$ $^{\circ}\text{C}$, the inground lights can adapt to a variety of indoor and outdoor temperature, humidity difference. They can be widely used in decoration of the buildings, stage, ancient buildings, shopping malls, hotel, cultural place and so on.

Greenough Enterprises Co., Ltd. is a professional inground light supplier. Please feel free to contact us for complete detail and data sheet.

Item: GNH-IG-

Power:0.3W;

Date: May. 7th, 2016



GNH-IG-0.3W-C



2. Product Introduction

Characteristics

1. Stainless steel +transparent PC cover
2. Good heat dissipation performance and waterproof design.
3. The unique optical PMMA clear lens ensure the brightness maintenance and projection effect.
4. High quality SMD as light source..
5. Exquisite appearance, beautiful designed.
6. Energy saving; life span over 50,000hours
7. Voltage in DC12V, safety to use for underwater or outdoor.
8. Emitting colors: single color-white, red, green, blue, and yellow. And RGB.

3. Specifications, parameters

Size detail:

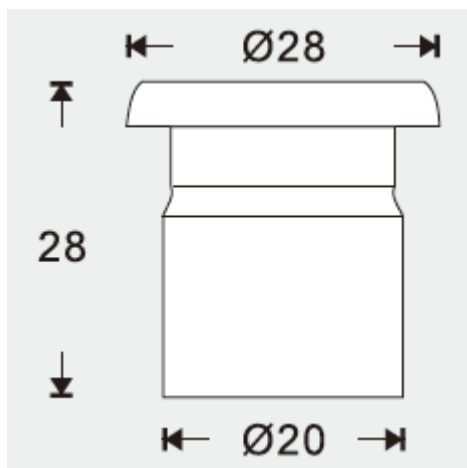



Greenough

Greenough Enterprises Co., Ltd.

LED luminaries Manufacturer and Exporter

Specification:

Item No.:	GNH-IG-0.3W-C	GNH-IG-0.3W-C
Wattage (W):	0.3W	0.3W
Voltage(V)	DC12V	
LED Type:	SMD2835	SMD5050
LED Quantity:	3pcs	1pcs
Color:	Red/ Green/ Blue/Yellow/ WW/ CW	RGB
Size:	Φ28*H28mm	
IP Rating	IP67	
Body Material	PC & Stainless Steel	
Ambient Temperature:	-30 ~ 65°C	
Control Method 1	-----	Four-wire Three-loop Circuit RGB controller + Remote Controller
Control Method 2	-----	Multifunctional RGB Controller
Matching Accessories	DC12V Constant Voltage Driver Power Supply	
	22AWG Wire with connectable waterproof plug	
		Four-wire Three-loop circuit RGB controller + remote controller / multifunctional RGB controller
Packing Detail:	100Pcs/Carton; Carton size:34X15X37CM	



4. Available accessories for this style:

You can buy the necessities one for your project.



5. Installation way:

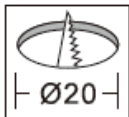

(without spring)

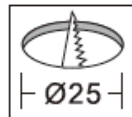

(with spring / sleeve)

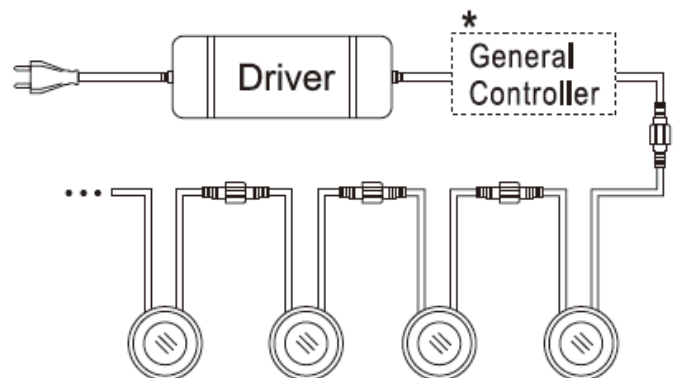
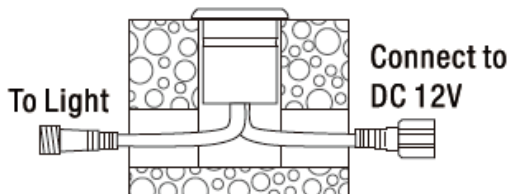

Set 1: Connect to Driver

Attention:

1. Warning: this lamp may only be used with the led light source provided.
2. Please connect the LED lamp to the driver before connecting the driver to the outlet or you may damage the LED light source.
3. Only clean surface with a mild cleaning agent using a soft cloth.



Greenough

Greenough Enterprises Co., Ltd.

LED luminaries Manufacturer and Exporter

6.Application:

It is widely used for Buildings, indoor, stairs, corridors, meeting rooms, showrooms, shopping malls, hotels and other places for decoration and lighting as well.

